

The RED Stamp **CPU-120C** Tote & Box Combo Packer integrates with our standard cigarette tax stamping machines. It automatically repacks the cigarette cartons into either case boxes, or totes for increased throughput and efficiency.

The RED Stamp **CPU-120C** Tote & Box Combo Packer dramatically improves the efficiency of the post-stamp operation for wholesalers that pick and stamp to order.



FEATURES

- ✓ Packs both boxes, and totes.
- ✓ Heavy-duty Construction.
- ✓ Industrial Duty Drives Motor and Gearbox.
- ✓ Able to Work Left Hand or Right Hand Sides.
- ✓ Adjustable Push Arm for Different Carton Widths.
- ✓ Cigarette Carton Tip and Back-up Censors to Prevent Jamming & for Reducing Carton Damage.
- ✓ Adjustable for all 6M Cases.
- ✓ Modem for Off-site Programming & Support.
- ✓ Computer Controlled, for Ultimate and Extreme Degree of Reliability and Upgradeability.
- ✓ PLC Indicates Exact Status of All Input and Output Signals.

OPERATOR INTERFACE



The **CPU-120C** includes an easy to use color touch screen control panel.

DESIGNED FOR MODULARITY

The RED Stamp CPU-120C Combo Packer is designed for flexibility and modularity: Allowing for flexibility in system layout and processing to suit your facility layout space requirements. **It offers automated operation, improved productivity, compact design, reduced operating cost, and heavy duty construction.**

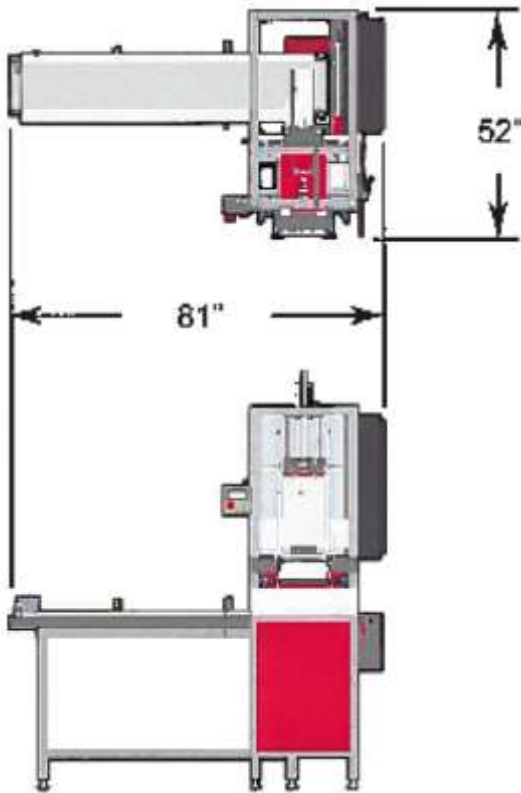

Electrical	110 VAC; 1 Phase, 10 Amp, 60 Hz	
Air Supply	6 CFM @ 90 PSI, Clean & Dry, ½" NPT Fitting	
Foot Print	Without Out-feed	With Out-feed
Depth	30"	81"
Width	52"	52"
Weight	600 lbs	750 lbs
Performance	100-140 cartons per minute	

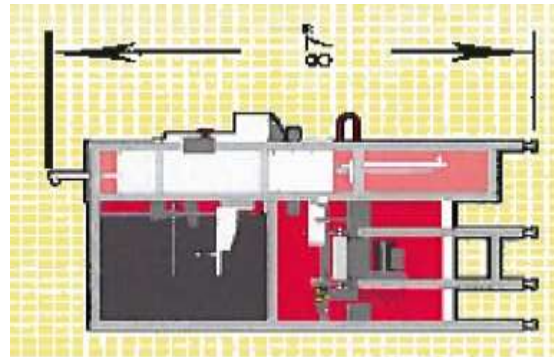

COMPLETE SYSTEM OPTIONS

Additional equipment available to work alongside this machine includes: In-feed Conveyor, Out-feed Conveyor, Case Splitters, Box Cutters, Cigarette Tax Stampers, Tote Strapping Units and Automatic Shrink Wrapping Systems.