

The RED Stamp **BSU-12M** Box Splitter is fully automated for splitting and presenting 12M cigarette cases. The splitter automatically differentiates a 12M case from all others. Correct sized boxes are diverted into the splitting station where they are split, and each half, presented with the cut-open side up. The box then continues back onto the main conveyor line.

The RED Stamp **BSU-12M** has a compact, modular design allowing for greater flexibility in system layout. It is a stand-alone machine that will easily integrate with our Case Cutter and/or Case Topping equipment – proving one of the most versatile systems available on the market.



FEATURES

- ✓ *Minimum Air Usage.*
- ✓ *Heavy-Duty Construction.*
- ✓ *Modular Design.*
- ✓ *PLC Controlled, for Ultimate Flexibility.*
- ✓ *PLC is Remotely Accessible for Updates and Troubleshooting.*
- ✓ *Fully Automated Operation.*
- ✓ *Color Touch Screen Operator Interface.*
- ✓ *Powder Coated Frame for Long Life.*
- ✓ *Splits an Estimated 7-8 Cases Per Minute.*
- ✓ *Ready to Integrate with our Case Cutter and Box Topper Units.*

OPERATOR INTERFACE

Each machine includes an easy to use, color touch screen control panel (training included in price), and was engineered for quick and easy adjustments through this touch screen application.



PH: 616-878-7771 **www.redstampinc.com** **Email: sales@redstampinc.com**

DESIGNED FOR MODULARITY

The RED Stamp **CSU-12M** Case Splitter's components are designed for modularity: Allowing for flexibility in system layout, to suite your facility.

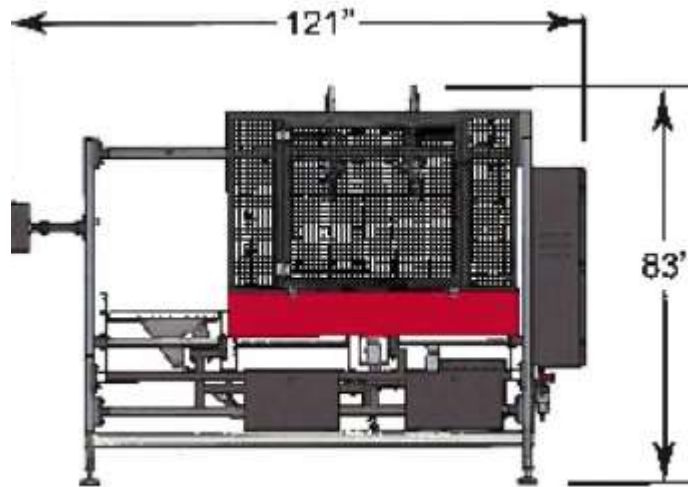
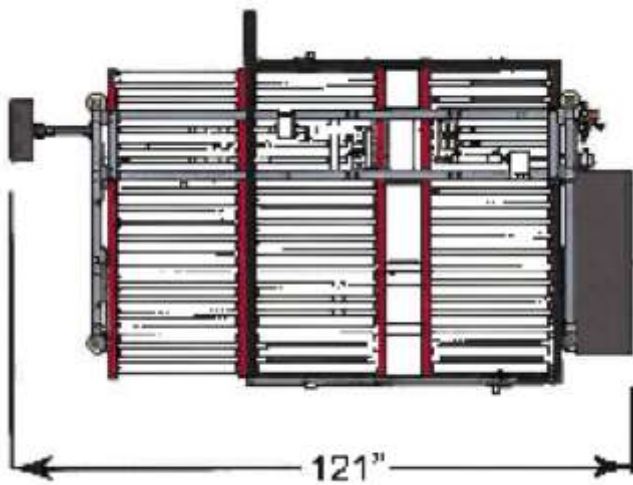

COMPLETE SYSTEM OPTIONS

Optional equipment is available to work alongside this machine, which includes: In-feed Conveyor Systems, Out-feed Conveyor Systems, Case Packers, Case Cutting Machines, Cigarette Tax Stampers, Conveyor Systems, Tote Strapping Units and Shrink Wrapping Systems.

